



US 20070238218A1

(19) **United States**

(12) **Patent Application Publication**
Teng et al.

(10) **Pub. No.: US 2007/0238218 A1**
(43) **Pub. Date: Oct. 11, 2007**

(54) **METHOD FOR FABRICATING ACTIVE MATRIX ORGANIC LIGHT EMITTING DIODE DISPLAY DEVICE AND STRUCTURE OF SUCH DEVICE**

Publication Classification

(51) **Int. Cl.**
H01L 51/40 (2006.01)
(52) **U.S. Cl.** **438/99**

(76) **Inventors:** **Te-Hua Teng**, Taoyuan County (TW);
Chia-Chien Chen, Taipei City (TW);
Fang-Yi Lu, Taoyuan County (TW);
Bing-Wei Wu, Taoyuan County (TW);
Yun-Pei Yang, Changhua County (TW)

(57) **ABSTRACT**

A method for fabricating an AMOLED display device is provided. A substrate is provided. A device layer having multiple active devices is formed on the substrate. A flat layer is configured on the device layer. A first, a second and a third color photoresistant layers are respectively configured on the flat layer and are patterned to form a first, a second and a third color filter layers. The first, the second and the third color filter layers respectively define a first, a second and a third pixel areas and are used for etching masks to etch the flat layer for exposing parts of the active devices. A first, a second and a third pixel electrode are respectively configured in the mentioned pixel areas and are electrically connected with the active devices. A first, a second and a third organic light emitting layers are respectively configured on the mentioned pixel electrodes.

Correspondence Address:
JIANQ CHYUN INTELLECTUAL PROPERTY OFFICE
7 FLOOR-1, NO. 100
ROOSEVELT ROAD, SECTION 2
TAIPEI 100 (TW)

(21) **Appl. No.: 11/308,561**
(22) **Filed: Apr. 7, 2006**

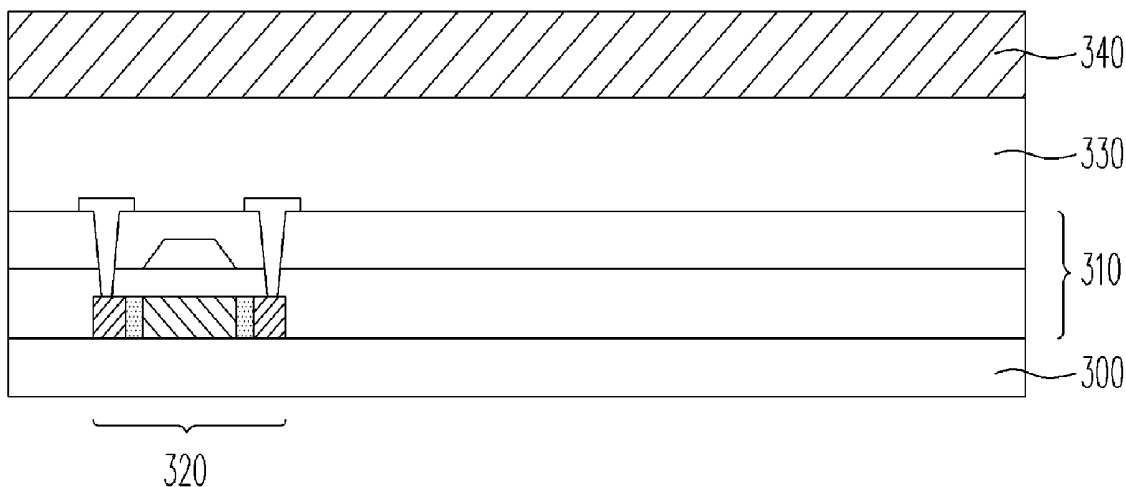

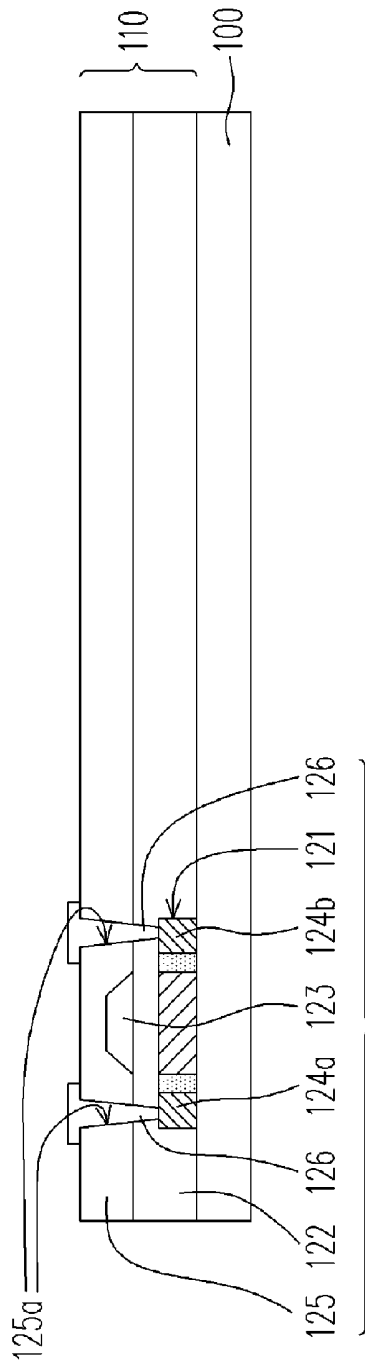

FIG. 1A(PRIOR ART)

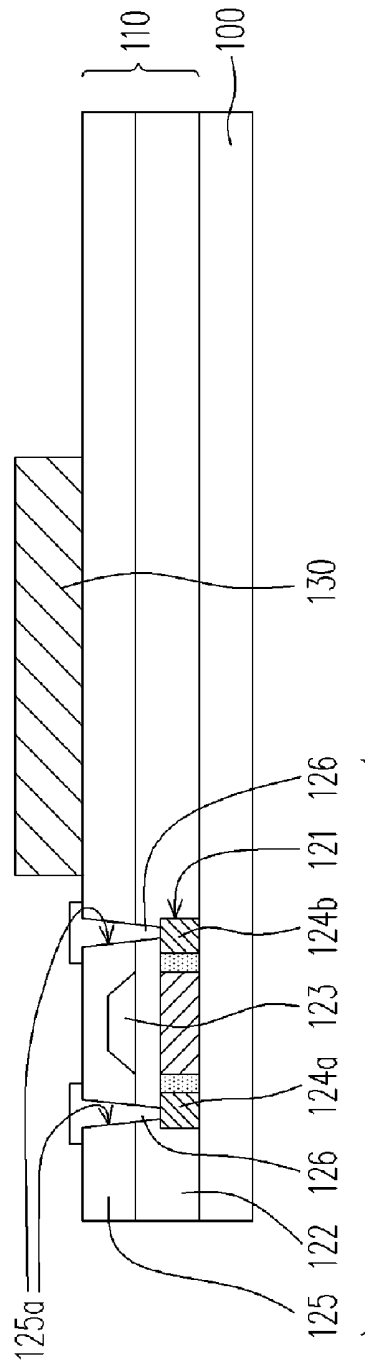

FIG. 1B(PRIOR ART)

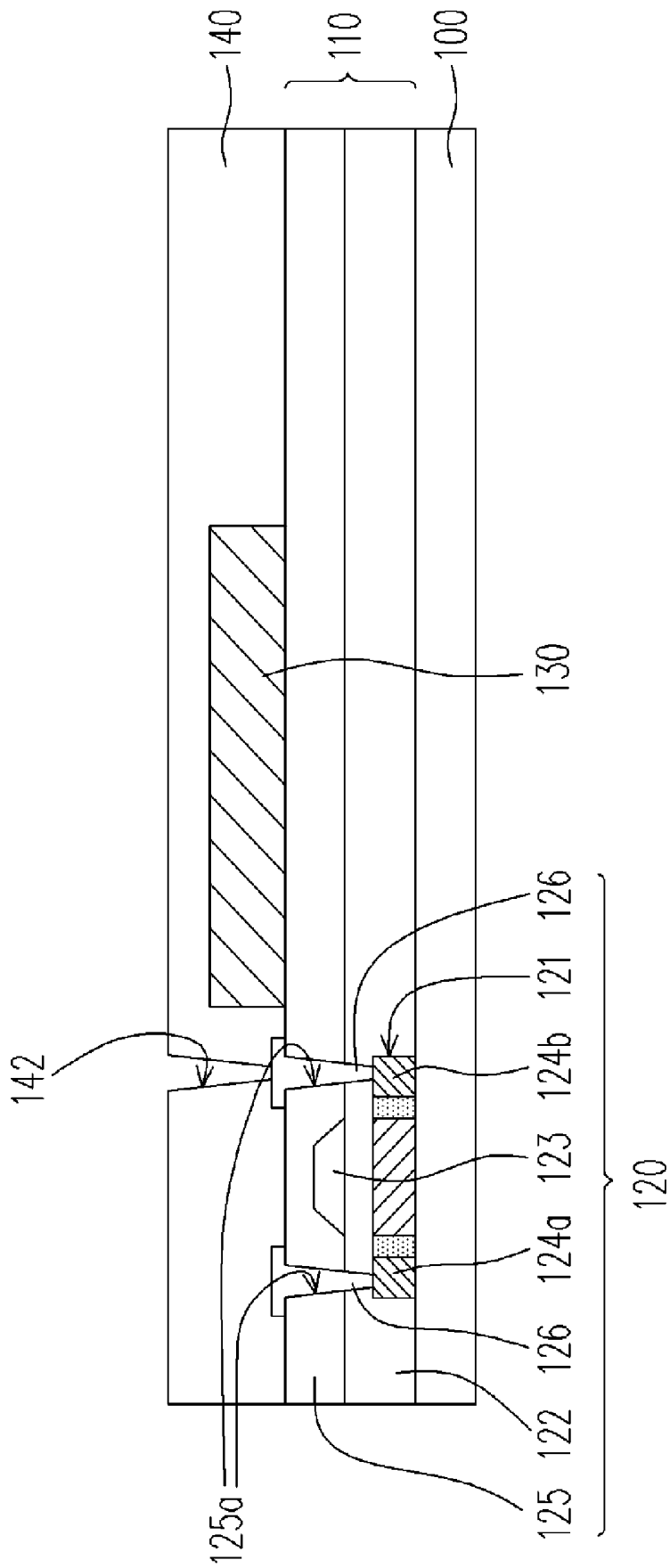

FIG. 1C(PRIOR ART)

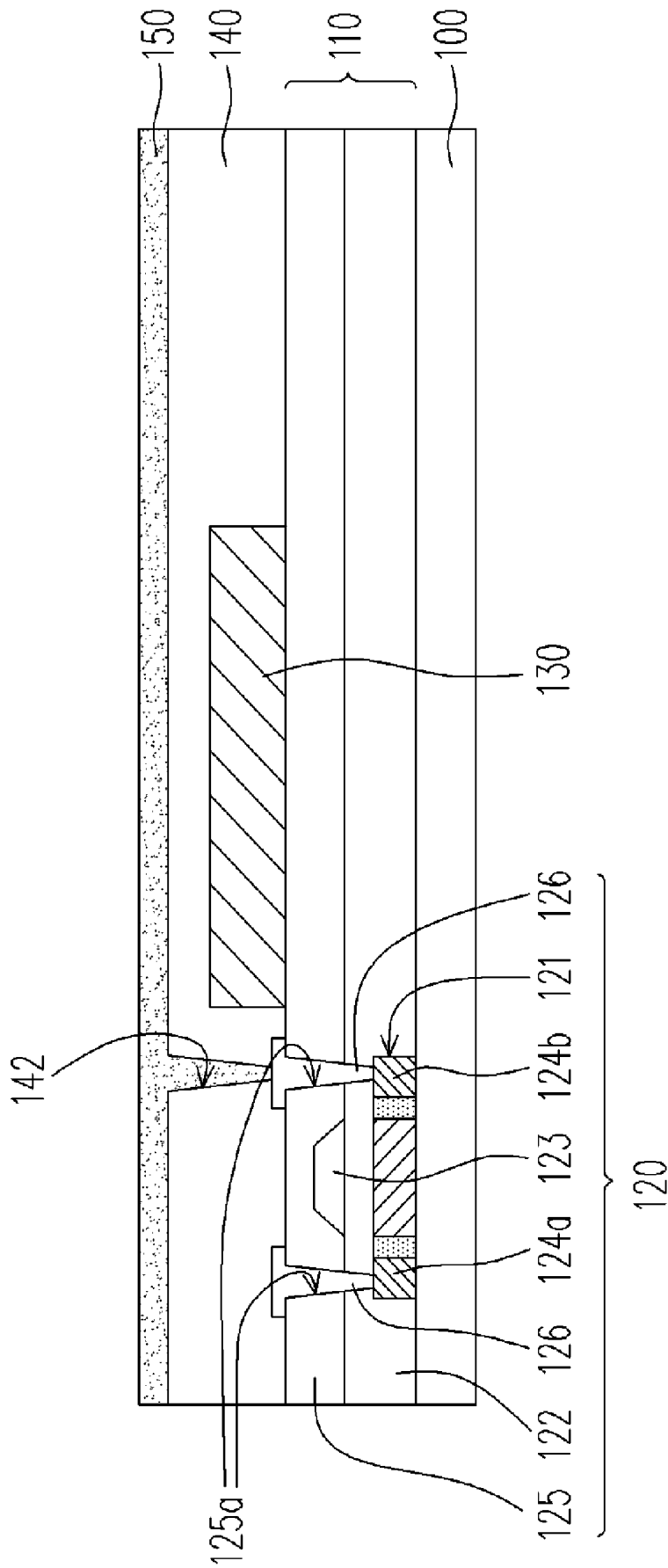

FIG. 1D(PRIOR ART)

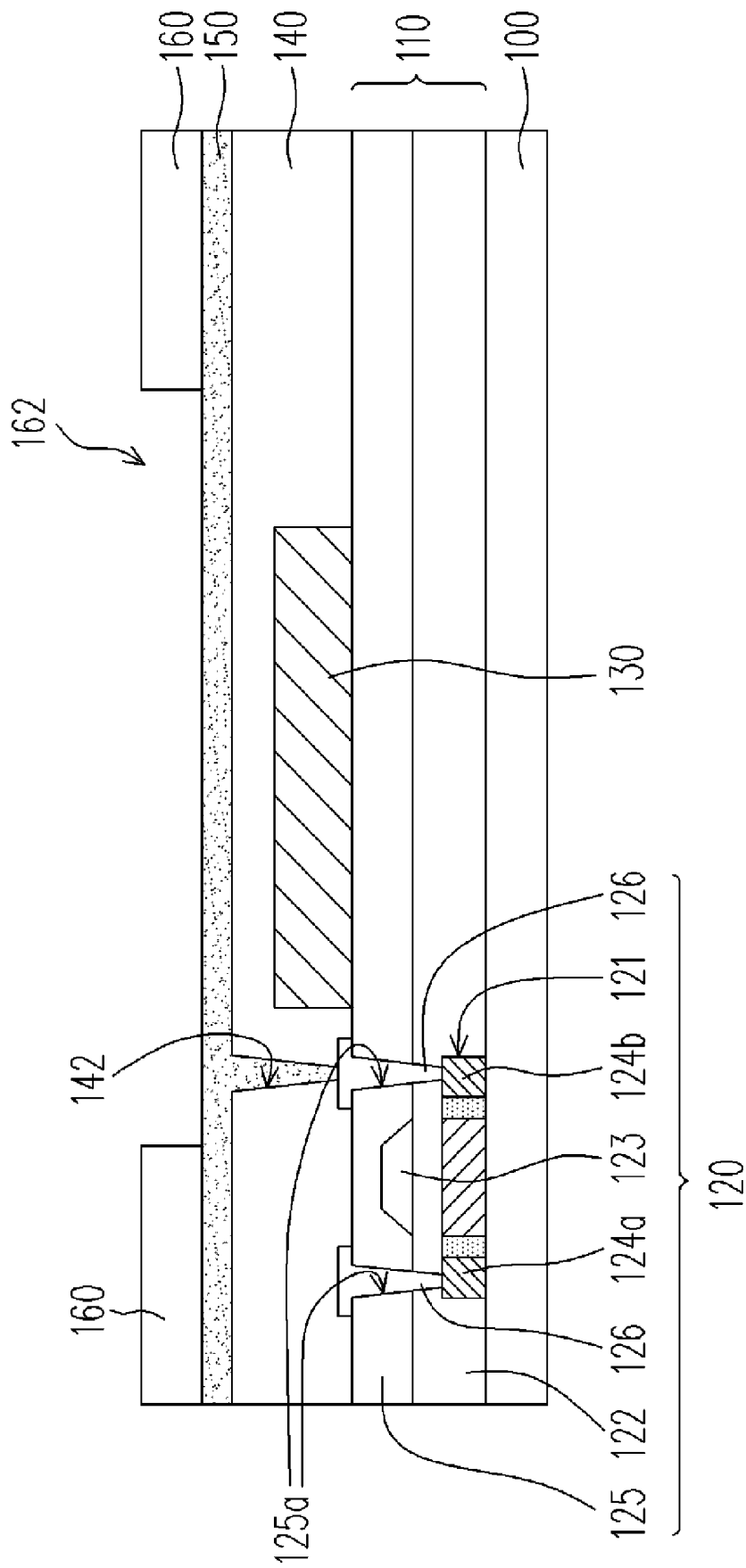

FIG. 1E(PRIOR ART)

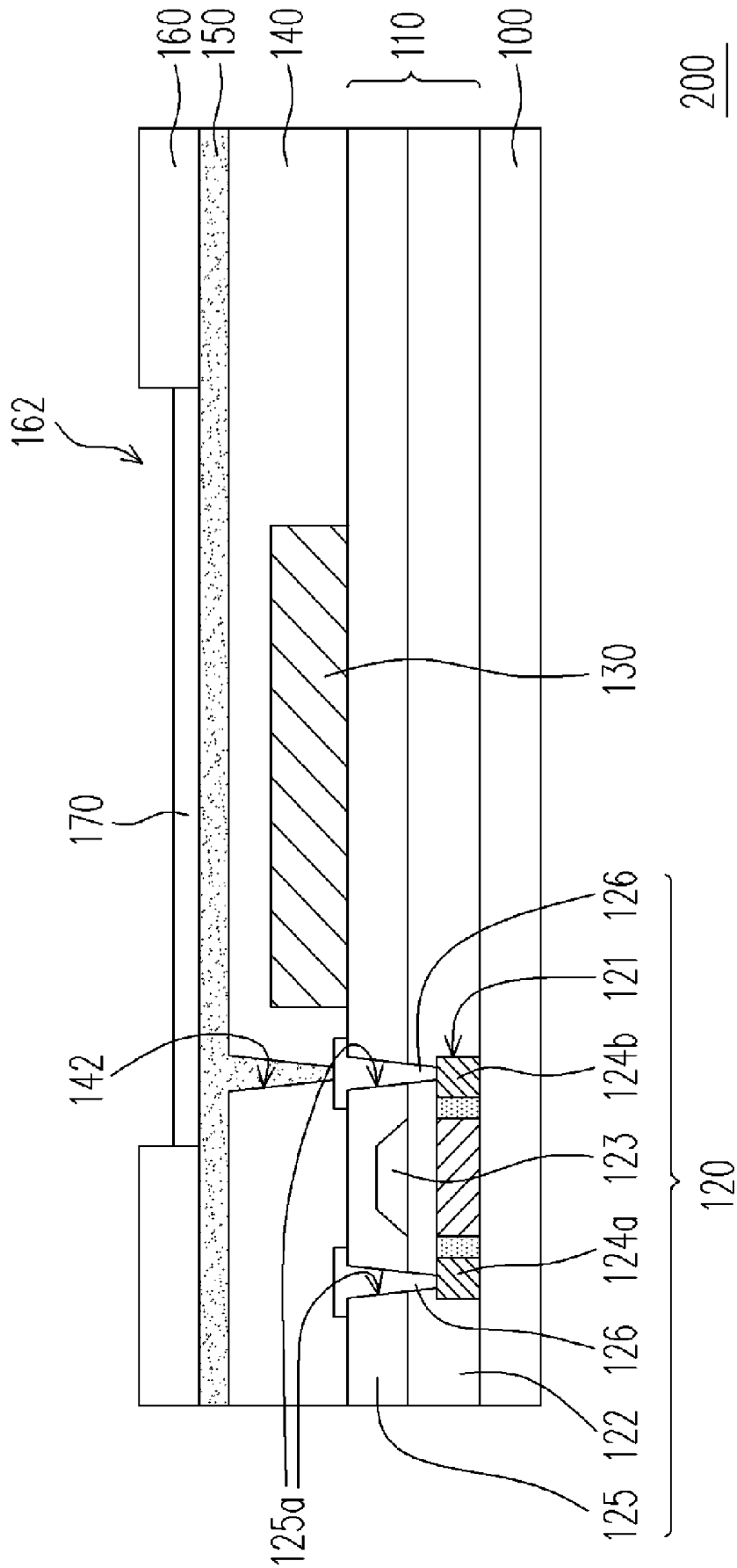

FIG. 1F(PRIOR ART)

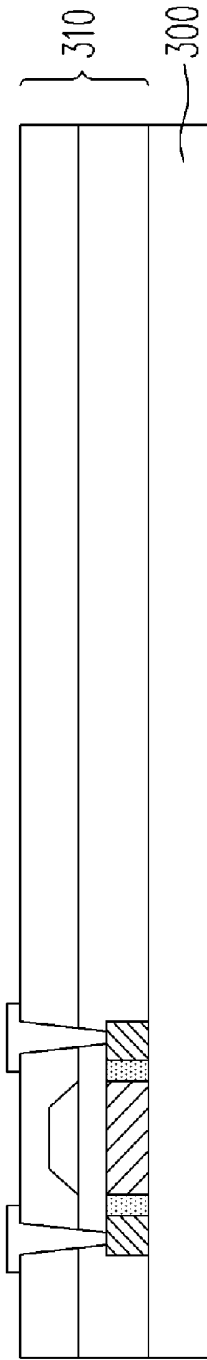

FIG. 2A

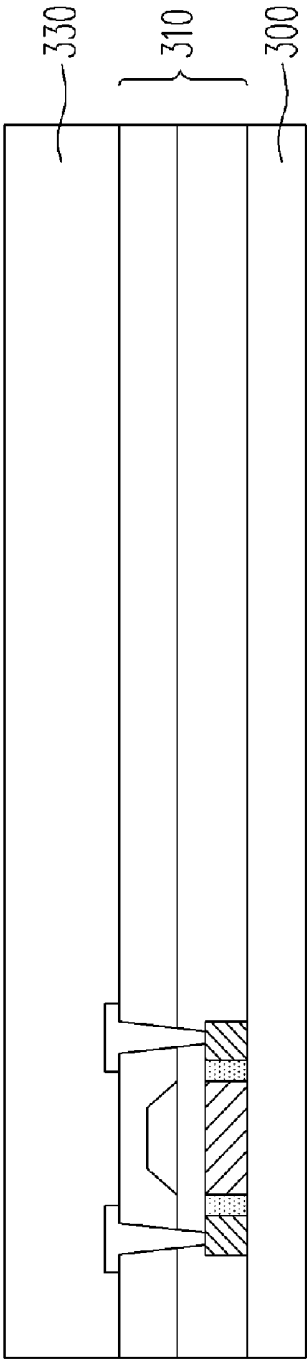

FIG. 2B

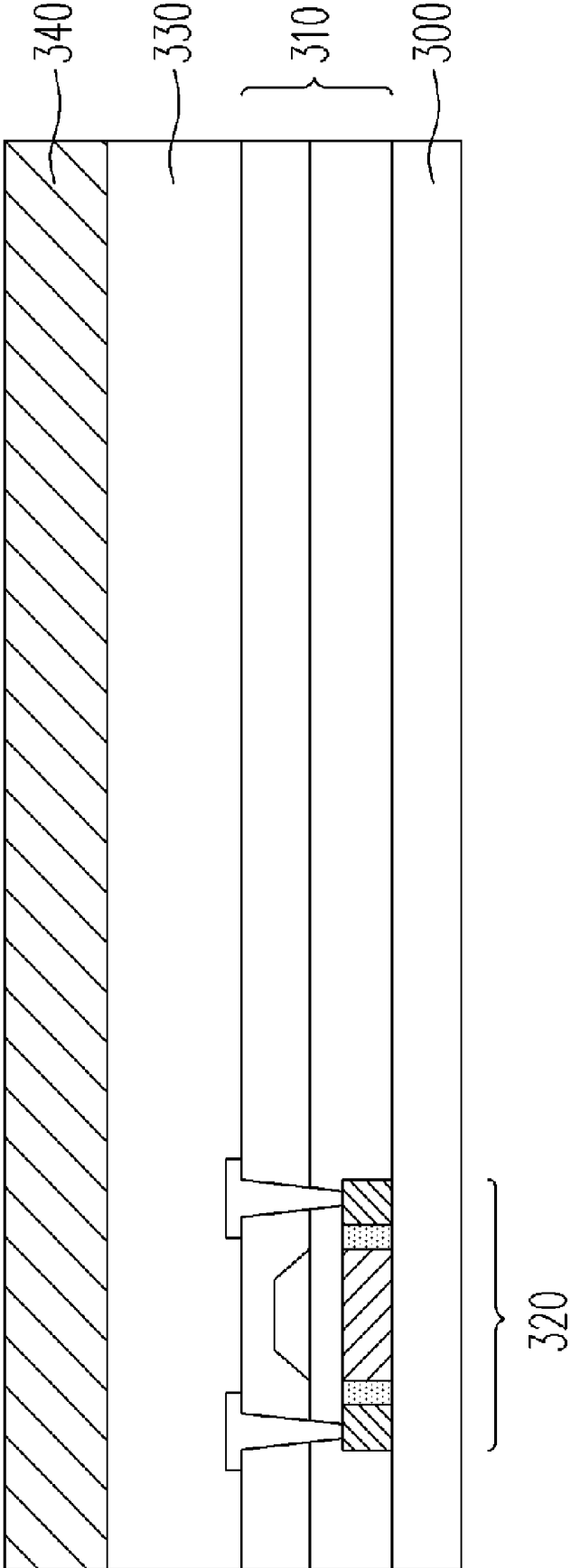

FIG. 2C

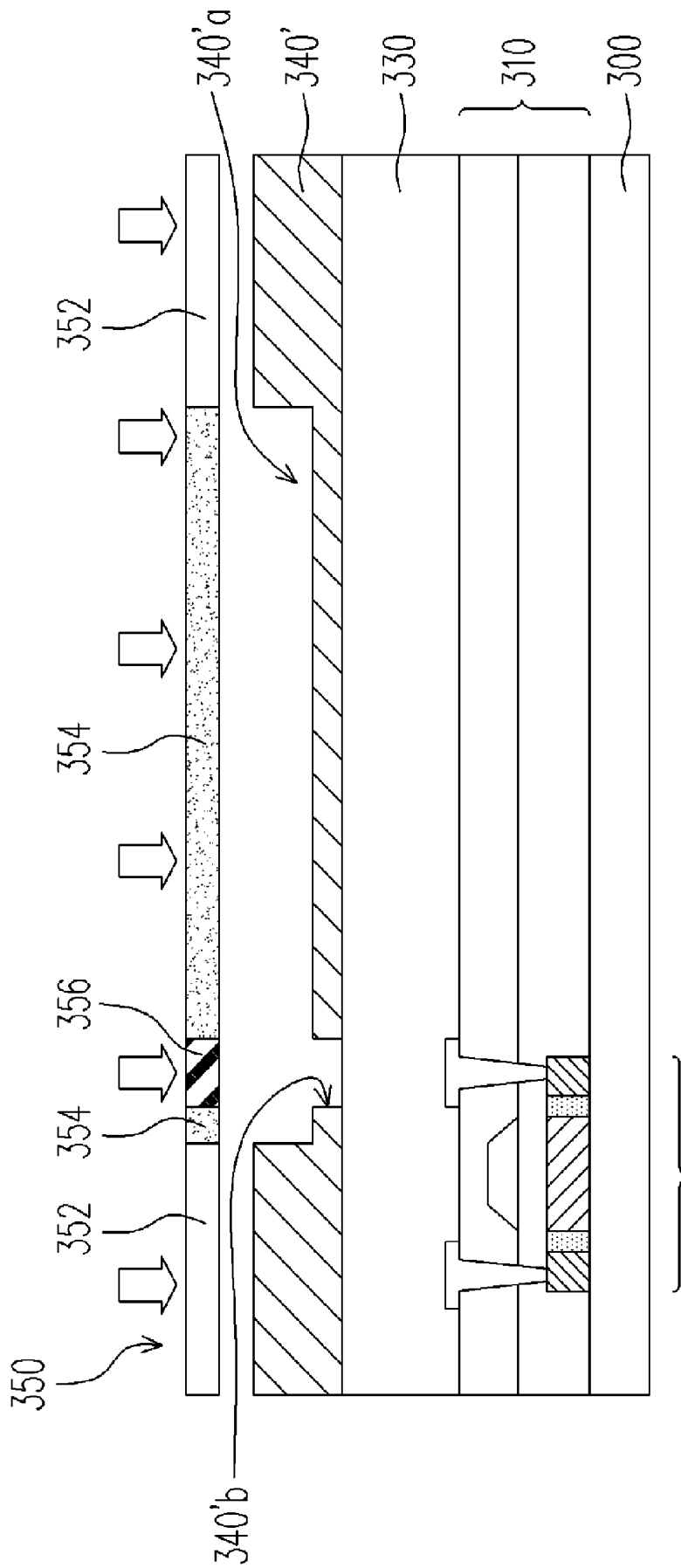

FIG. 2D

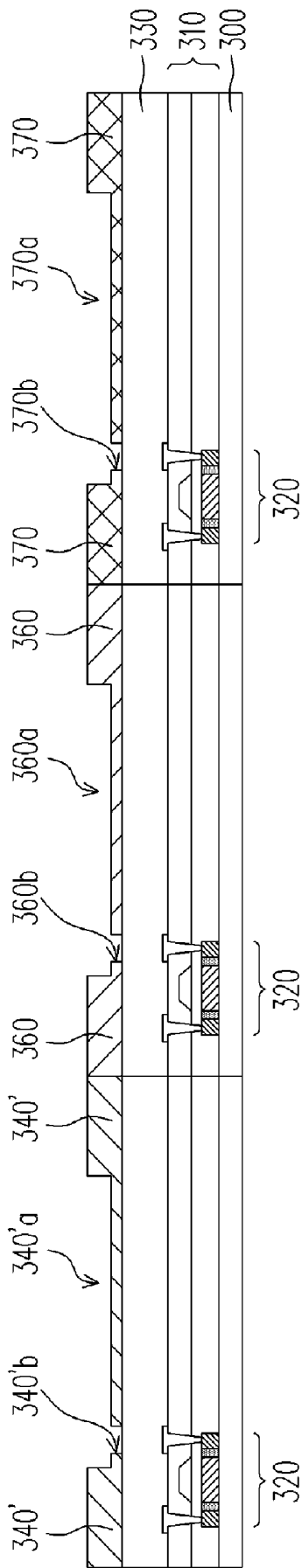

FIG. 2E

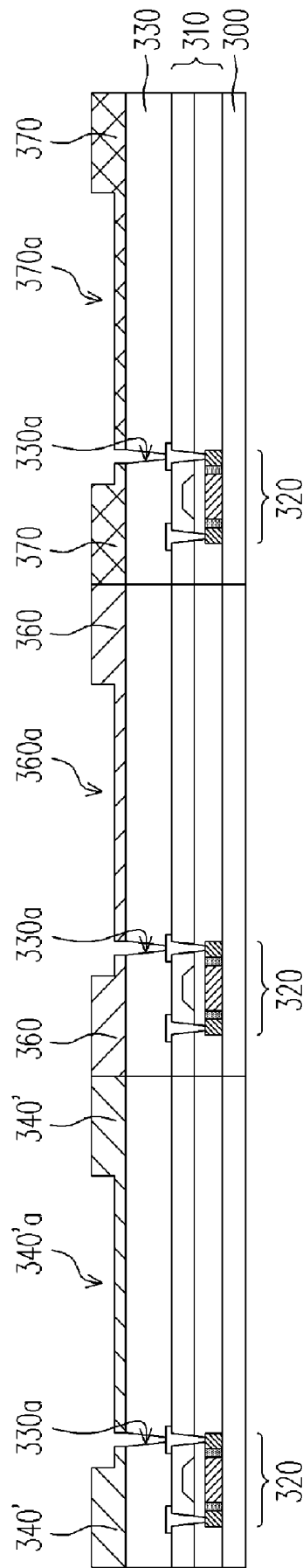

FIG. 2F

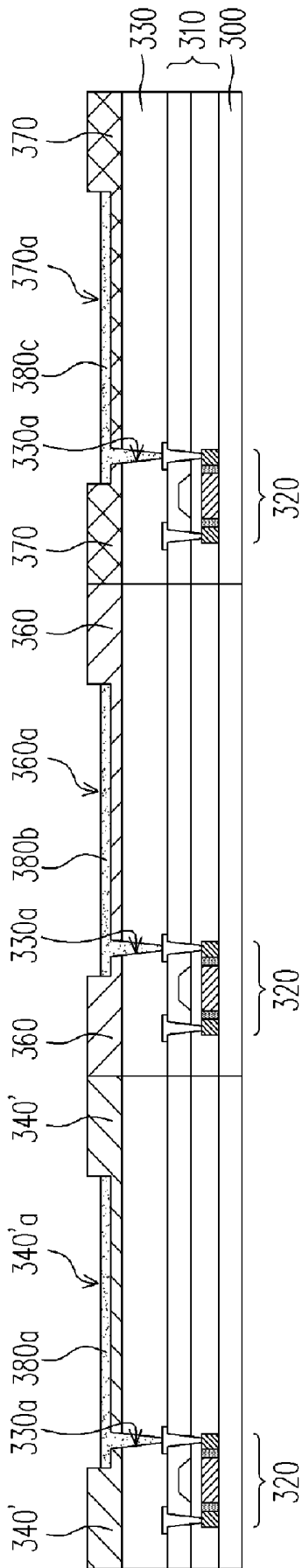

FIG. 2G

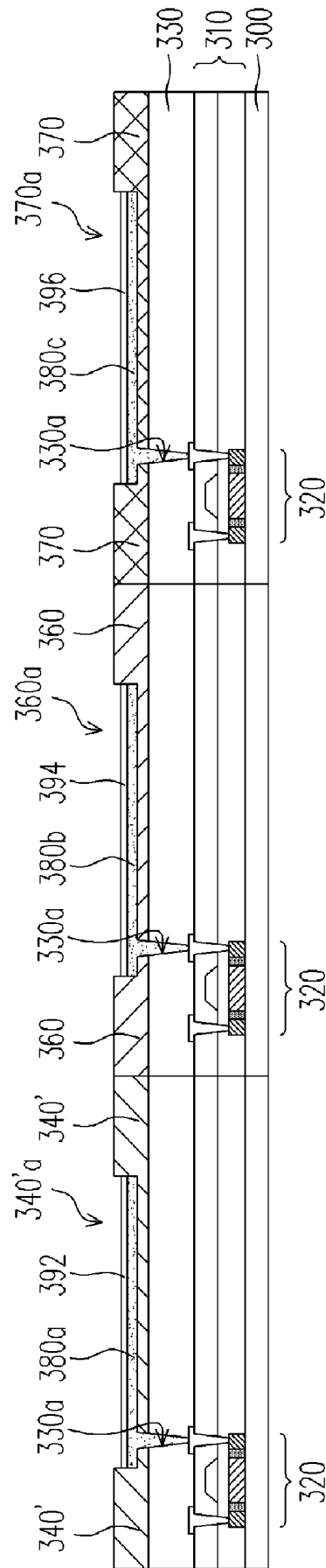

FIG. 2H

METHOD FOR FABRICATING ACTIVE MATRIX ORGANIC LIGHT EMITTING DIODE DISPLAY DEVICE AND STRUCTURE OF SUCH DEVICE

BACKGROUND OF THE INVENTION

[0001] 1. Field of the Invention

[0002] The present invention relates to a method for fabricating an Active Matrix Organic Light Emitting Diode (AMOLED) display device and a structure of such device, and particularly to a method for fabricating an AMOLED display device and a structure thereof, in which color filter layers are processed by a half-tone mask.

[0003] 2. Description of Related Art

[0004] An Organic Light Emitting Diode (OLED) is a semiconductor device capable of efficiently converting electrical energy into optical energy. OLEDs are widely used as luminous elements in indication lights, display panels and optical reading/writing heads. Wherein, OLED display devices, having advantages such as free-viewing angles, simple processing, low production cost, fast response, wide operation temperature range and full color displaying, meet the demands of modern display devices in the multimedia field. So, in recent years, OLEDs are being enthusiastically researched and developed.

[0005] An AMOLED display device having a structure of color filter on array (COA) has been proposed. The fabricating methods and structures related to the AMOLED are also developed and proposed by many scholars. FIGS. 1A through 1F are schematic cross-sectional views illustrating a process for fabricating a conventional AMOLED display device having a structure of COA.

[0006] Referring to FIG. 1A, a substrate 100 is prepared. The substrate 100 has a device layer 110 configured thereon. The device layer 110 includes a plurality of thin film transistors (TFT) 120 (only one exemplarily shown), a plurality of scan lines (not shown) and a plurality of data lines (not shown). The TFTs 120 are driven by the scan lines and the data lines.

[0007] Referring to FIG. 1A, each TFT 120 includes a silicon island 121, a gate-insulating layer 122, a gate electrode 123, a source electrode 124a, a drain electrode 124b, an inter-layer dielectric (ILD) layer 125, and a source/drain contact metal 126. The ILD layer 125 has an opening 125a configured for exposing the source electrode 124a and the drain electrode 124b of the TFT 120. The source/drain contact metal 126 is electrically connected with the source electrode 124a and the drain electrode 124b. The source/drain contact metal 126 is adapted for electrically connecting the TFT 120 with a sequentially formed transparent conductive layer 150.

[0008] Referring to FIG. 1B, the ILD layer 125 is taken as a buffer layer for making a color filter array, that is the foregoing mentioned COA structure. Three times of procedures including coating color light resistant, exposing and photolithography are processed for respectively forming a red color filter layer 130, a green color filter layer (not shown) and a blue color filter layer (not shown) on the ILD layer 125. It is to be noted that the positions of the red color filter layer 130, the green color filter layer and the blue color

filter layer are respectively corresponding to the subsequently formed pixel areas 162.

[0009] Now referring to FIG. 1C, a flat layer 140 is then formed on the substrate 100. The flat layer 140 covers the red color filter layer 130, the green color filter layer (not shown) and the blue color filter layer (not shown). Then, the flat layer 140 is patterned for forming a contact window opening 142, which exposes the source/drain contact metal 126.

[0010] Referring to FIG. 1D, a transparent conductive layer 150 is formed on the flat layer 140. The transparent conductive layer 150 is electrically connected with the source/drain contact metal 126 via the contact window opening 142.

[0011] Referring to FIG. 1E, a pixel defining layer 160 is then formed on the transparent conductive layer 150, for defining a plurality of pixel areas. The pixel defining layer 160 is generally formed by either coating an organic photoresistant layer, followed by exposure and photolithography; or coating an inorganic layer and then processing procedures of photolithography and etching.

[0012] Then referring to FIG. 1F, an organic light emitting layer 170 is formed in the pixel area 162 and thus completing the fabrication of the AMOLED display device 200. The organic light emitting layer 170 is controlled to emit light by switching actions of the TFT 120 to apply voltages on the transparent conductive layer 150. Light emitted from the organic light emitting layer 170 is therefore filtered by the color filter array layer (as the red color filter layer 130 shown in the drawings) to be color light.

[0013] It is to be noted that the process for fabricating the color filter array layer of the foregoing AMOLED display device 200 having COA structure requires three times of procedures including coating color photoresistant layer, exposing and photolithography. Further, a process of patterning the flat layer 140 to configure the contact window opening 142 is needed for electrically connecting the TFT 120 with the transparent conductive layer 150. Furthermore, another procedure including coating and patterning processes is also needed for configuring a pixel defining layer 170, which is required for defining the pixel areas 162, in which the organic light emitting layers 170 are to be coated.

[0014] According to the foregoing, the fabrication of the conventional AMOLED display device 200 having COA structure is complicated and the production cost thereof is unlikely to be lowered.

SUMMARY OF THE INVENTION

[0015] Therefore, an object of the present invention is to provide a method for fabricating an AMOLED display device, which simplifies the fabricating process and lowers the production cost thereof.

[0016] Another object of the present invention is to provide an AMOLED display device fabricated with the foregoing method and thus improve the productivity.

[0017] For achieving the foregoing objects and others, the present invention provides a method for fabricating an AMOLED display device, which includes the following steps. First, a substrate is provided. After that, a device layer is configured on the substrate, wherein the device layer

includes a plurality of active devices. Then, a flat layer is configured on the device layer. Then, a first color photoresistant layer is configured on the flat layer. Then, a first color filter layer is configured by patterning the first color photoresistant layer, and the first color filter layer has a first pixel area and a first opening. Next, a second color photoresistant layer is configured on the flat layer. A second color filter layer is then configured by patterning the second color photoresistant layer, and the second color filter layer has a second pixel area and a second opening. Then, a third color photoresistant layer is configured on the flat layer. A third color filter layer is then configured by patterning the third color photoresistant layer, and the third color filter layer has a third pixel area and a third opening. Then, the first, the second and the third color filter layers are used as masks, parts of the flat layer respectively under the first, the second and the third openings are removed for configuring a plurality of contact window openings for exposing parts of the active devices. Afterward, a first pixel electrode, a second pixel electrode and a third pixel electrode are respectively configured in the first, the second and the third pixel areas. The first pixel electrode, the second pixel electrode and the third pixel electrode are respectively electrically connected with the active devices via the contact window openings. Finally, a first organic light emitting layer, a second organic light emitting layer and a third organic light emitting layer are respectively configured on the first pixel electrode, the second pixel electrode and the third pixel electrode.

[0018] According to an embodiment of the invention, the foregoing process of patterning the first, the second and the third color photoresistant layers includes patterning the first, the second and the third color photoresistant layers with a half-tone mask.

[0019] According to an embodiment of the invention, the foregoing first color filter layer is a red color filter layer; the second color filter layer is a green color filter layer; and the third color filter layer is a blue color filter layer.

[0020] According to an embodiment of the invention, the foregoing first, second and third organic light emitting layers are different in composition, wherein the first organic light emitting layer is a red organic light emitting layer; the second organic light emitting layer is a green organic light emitting layer; and the third organic light emitting layer is a blue organic light emitting layer.

[0021] According to an embodiment of the invention, the foregoing first, second and third organic layers are identical in composition, wherein all of the first, the second and the third organic layers are white organic light emitting layers.

[0022] To achieve the foregoing objects and others, the present invention also provides an AMOLED display device. The AMOLED display device includes a substrate, a device layer, a flat layer, a first, a second, and a third color filter layers, a first, a second and a third pixel electrodes, a first, a second and a third organic light emitting layers. The device layer is configured on the substrate, and the device layer includes a plurality of active devices. The flat layer is configured on the device layer, and the flat layer includes a plurality of contact window openings for exposing parts of the foregoing active devices. The first color filter layer is configured on the flat layer, and the first color filter has a first pixel area and a first opening. Wherein, the first opening is configured above a part of the contact window openings.

The second color filter layer is configured on the flat layer, and the second color filter layer has a second pixel area and a second opening. Wherein, the second opening is configured above a part of the contact window openings. The third color filter layer is configured on the flat layer, and the third color filter layer has a third pixel area and a third opening. The third opening is configured above a part of the contact window openings. The first, the second and the third pixel electrodes are disposed respectively in the first, the second and the third pixel areas. The first, the second and the third pixel electrodes are respectively electrically connected to the active devices via the contact window openings and the first, the second and the third openings, respectively. The first, the second and the third organic light emitting layers are respectively configured on the first, the second and the third pixel electrodes.

[0023] According to an embodiment of the invention, the foregoing first color filter layer is a red color filter layer; the second color filter layer is a green color filter layer; and the third color filter layer is a blue color filter layer.

[0024] According to an embodiment of the invention, the foregoing first, second and third organic light emitting layers are different in composition, wherein the first organic light emitting layer is a red organic light emitting layer; the second organic light emitting layer is a green organic light emitting layer; and the third organic light emitting layer is a blue organic light emitting layer.

[0025] According to an embodiment of the invention, the foregoing first, second and third organic layers are identical in composition, wherein all of the first, the second and the third organic layers are white organic light emitting layers.

[0026] According to an embodiment of the invention, the foregoing device layer further includes a plurality of scan lines and a plurality of data lines, by which the active devices can be driven.

[0027] According to an embodiment of the invention, the foregoing active devices includes TFTs. Each of the TFTs includes a silicon island, a gate-insulating layer, a gate electrode, a source/drain electrode, an inter-layer dielectric (ILD) layer, and a source/drain contact metal. The silicon island is disposed on the substrate, and the gate-insulating layer covers the silicon island. The gate electrode is configured on the gate-insulating layer above the silicon island, and the source/drain electrode are configured in the silicon island under two sides of the gate electrode. A channel area is defined between the source/drain electrode. The ILD layer is configured covering the gate electrode and exposes a part of the source/drain electrode. The source/drain contact metal is electrically connected respectively with the source/drain electrode. A lightly doped drain (LDD) area may be advantageously included between the channel area and the source/drain electrode.

[0028] According to an embodiment of the invention, the foregoing first, second and third pixel electrodes are made of indium tin oxide (ITO) or indium zinc oxide (IZO).

[0029] The present invention employs a half-tone mask to pattern the first, the second and the third color photoresistant layers, thus the subsequently obtained first, second and third color filter layers can be used as pixel defining layers and etching masks for making the contact window openings. The method for fabricating an AMOLED display device is

adapted for simplifying fabricating procedures and lowering production cost by skipping over the process of making pixel defining layers and etching masks for making the contact window openings.

BRIEF DESCRIPTION OF THE DRAWINGS

[0030] The features of the invention which are believed to be novel are set forth with particularity in the appended claims. The invention, together with its objects and the advantages thereof, may be best understood by reference to the following description taken in conjunction with the accompanying drawings, in which like reference numerals identify like elements in the figures and in which:

[0031] FIGS. 1A through 1F are schematic cross-sectional views illustrating a process for fabricating a conventional AMOLED display device having a structure of COA.

[0032] FIGS. 2A through 2H are schematic cross-sectional views illustrating a process for fabricating an AMOLED display device according to an embodiment of the present invention.

[0033] FIG. 3 is a schematic cross-sectional view of an AMOLED display device according to an embodiment of the present invention.

DESCRIPTION OF THE EMBODIMENTS

[0034] FIGS. 2A through 2H are schematic cross-sectional views illustrating a process for fabricating an AMOLED display device according to an embodiment of the present invention. Referring to FIGS. 2A through 2H, the method for fabricating an AMOLED display device according to an embodiment of the present invention is illustrated as below.

[0035] First, a substrate 300 is provided as shown in FIG. 2A. The substrate 300, for example, is glass substrate, quartz substrate or flexible substrate. Then, referring to FIG. 2A again, a device layer 310 is configured on the substrate. The device layer 310 includes a plurality of active devices 320 (only one shown in FIG. 2A). According to an embodiment of the invention, the active devices 320, for example, are thin film transistors (TFTs). And, the device layer 310 includes a plurality of scan lines (not shown) and data lines (not shown), by which the active devices 320 can be driven. The method for forming the device layer 310 is utilized by normal semiconductor process and will not be described in detail.

[0036] A flat layer 330 is then configured on the device layer 310, as illustrated in FIG. 2B. According to an embodiment, chemical vapor deposition (CVD) is used for configuring the flat layer 330, and the material of the flat layer 330, for example, is silicon dioxide, silicon nitride or silicon nitride oxide.

[0037] Turning to FIG. 2C, a first color photoresistant layer 340 is configured on the flat layer 330. According to an embodiment, the method for configuring the first color photoresistant layer 340, for example, is spin coating or evaporation, and the material of the first color photoresistant layer 340, for example, is a polymer material.

[0038] Then, the first color photoresistant layer 340 is patterned to configure a first color filter layer 340' and to define a first pixel area 340'a, and the first color filter layer 340' has a first opening 340'b as shown in FIG. 2D. Accord-

ing to an embodiment of the invention, the first color photoresistant layer 340 is patterned, for example, with a half-tone mask 350.

[0039] As illustrated in FIG. 2D, the half-tone mask 350, for example, includes an exposing area 352, a half-tone area 354 and a light shading area 356. The first color photoresistant layer 340 can be either a negative type photoresist or a positive type photoresist. If the first color photoresistant layer 340 is a negative type photoresist, after a photolithography processing is performed to the first color photoresistant layer 340 using the half-tone mask 350 as an optical mask, parts of the first color photoresistant layer 340 corresponding to the exposing area 352 are intact; some other parts of the first color photoresistant layer 340 corresponding to the half-tone area 354 are partly removed to configure the first pixel area 340'a; and the other parts of the first color photoresistant layer 340 corresponding to the light shading area 356 are entirely removed to configure the first opening 340'b, thus obtaining the first color filter layer 340'. Besides, according to another embodiment of the invention, the first color photoresistant layer 340 can be patterned to form the first color filter layer 340' shown in FIG. 2D by two or more optical masks with different exposure energy.

[0040] Next, the steps illustrated in FIGS. 2C and 2D are repeated to configure a second color photoresistant layer (not shown) on the flat layer 330 and to subsequently configure a second color filter layer 360 by patterning the second color photoresistant layer with the half-tone mask 350. Similarly, a third color photoresistant layer (not shown) is further configured of the foregoing on the flat layer 330 and a third color filter layer 370 is then subsequently configured by patterning the third color photoresistant layer with the half-tone mask 350, and thus a structure of color filter on array (COA) as shown in FIG. 2E is configured. In a same manner, the second color filter layer 360 defines a second pixel area 360'a and has a second opening 360'b, and the third color filter layer 370 defines a third pixel area 370'a and has a third opening 370'b. According to an embodiment of the invention, the first color filter layer 340' is a red color filter layer; the second color filter layer 360 is a green color filter layer; and the third color filter layer 370 is a blue color filter layer, all of which configure a color filter array layer.

[0041] It is to be noted that the first, the second and the third color filter layers 340', 360 and 370 made by the steps of photoresist coating, exposing and photolithography with the half-tone mask 350 are not only functioned as color filters, but also used as pixel defining layer for defining a plurality of first, second and third pixel areas 340'a, 360'a and 370'a.

[0042] Then, the first, the second and the third color filter layers 340', 360 and 370 are used as masks to remove parts of the flat layer 330 under the first, the second and the third openings 340'b, 360'b and 370'b for configuring a plurality of contact window openings 330'a. The contact window openings 330'a expose parts of the active devices 320 as illustrated in FIG. 2F. According to an embodiment of the invention, the method for removing the parts of the flat layer 330, for example, is either dry etching or wet etching.

[0043] It is to be noted that having the first, the second and the third color filter layers 340', 360 and 370 having the first, the second and the third openings 340'b, 360'b and 370'b can be used as etching masks for making the contact window

openings **330a**. As a result, comparing with the conventional technology shown in FIG. 1C, the present invention skips a step of patterning the photoresistant layer for making the contact window openings **330a**, thus the procedures of the present invention is relatively simple.

[0044] Next, as illustrated in FIG. 2G, a first, a second and a third pixel electrodes **380a**, **380b** and **380c** are respectively configured in the first, the second and the third pixel areas **340a**, **360a** and **370a**; the first, the second and the third pixel electrodes **380a**, **380b** and **380c** are electrically connected to the active devices **320** respectively via the contact window openings **330a**. According to an embodiment of the invention, the method for configuring the first, the second and the third pixel electrodes **380a**, **380b** and **380c**, for example, is sputtering a transparent conductive layer (not shown) onto the substrate **300** and then patterning the transparent conductive layer and therefore configuring the first, the second and the third pixel electrodes **380a**, **380b** and **380c**. The material of the transparent conductive layer, for example, is either indium tin oxide (ITO) or indium zinc oxide (IZO).

[0045] Now turning to FIG. 2H, a first, a second and a third organic light emitting layers **392**, **394** and **396** are respectively configured on the first, the second and the third pixel electrodes **380a**, **380b** and **380c**. According to an embodiment of the invention, the method for configuring the first, the second and the third pixel electrodes **380a**, **380b** and **380c**, for example, is evaporation.

[0046] Referring to FIG. 2H, the first, the second and the third organic light emitting layers **392**, **394** and **396** can be different in composition, i.e., the colors of the above organic light emitting layers **392**, **394** and **396** can be different. And the first, the second and the third organic light emitting layers **392**, **394** and **396** are preferably configured in corresponding to the colors of respectively the first, the second and the third color filter layers **340**, **360** and **370**. According to an embodiment of the invention, the first organic light emitting layer **392** is a red organic light emitting layer; the second organic light emitting layer **394** is a green organic light emitting layer; and the third organic light emitting layer **396** is a blue organic light emitting layer, thus a better color saturation performance can be achieved.

[0047] According to another embodiment of the invention, the first, the second and the third organic light emitting layers **392**, **394** and **396** can also be identical in composition, i.e., the colors of the above organic light emitting layers **392**, **394** and **396** can be identical. The first, the second and the third organic light emitting layers **392**, **394** and **396** can be white organic light emitting layers or organic light emitting layers of other colors. Therefore, the production procedure can be simplified and the production cost can be lowered accordingly.

[0048] In view of the foregoing, the present invention employs a half-tone mask for patterning the first, the second and the third color photoresistant layers, thus the subsequently obtained first, second and third color filter layers can be used as pixel defining layers and etching masks for making the contact window openings. In comparison with the conventional technologies, the procedure of the method for fabricating an AMOLED display device is simplified and the production cost is reduced by skipping over the process of making pixel defining layers and etching masks for making the contact window openings.

[0049] FIG. 3 is a schematic cross-sectional view of an AMOLED display device according to an embodiment of the present invention. Such an AMOLED display device **400** includes a substrate **410**, a device layer **420**, a flat layer **430**, a first, a second and a third color filter layers **442**, **444** and **446**, a first, a second and a third pixel electrodes **452**, **454** and **456**, and a first, a second, a third organic light emitting layers **462**, **464** and **466**.

[0050] Referring to FIG. 3, the device layer **420** is configured on the substrate **410**, and the device layer **420** includes a plurality of active devices **470**. According to an embodiment of the invention, the device layer **420** further includes a plurality of scan lines (now shown) and a plurality of data lines (not shown), by which the active devices **470** are driven. The active devices **470** are, for example, TFTs. According to an embodiment of the invention, each of the TFTs includes a silicon island **471**, a gate-insulating layer **472**, a gate electrode **473**, a source/drain electrode **474a/474b**, an inter-layer dielectric (ILD) layer **475**, and source/drain contact metals **476**. The silicon island **471** is disposed on the substrate **410**, and the gate-insulating layer **472** covers the silicon island **471**. The gate electrode **473** is configured on the gate-insulating layer **472** above the silicon island **471**, and the source/drain electrode **474a/474b** are configured in the silicon island **471** under two sides of the gate electrode **473**. A channel area **474c** is defined between the source/drain electrode **474a/474b**. The ILD layer **475** is configured covering the gate electrode **473** and exposing a part of the source/drain electrode **474a/474b**. The source/drain contact metals **476** are respectively electrically connected with the source/drain electrode **474a/474b**. Besides, a lightly doped drain (LDD) area **480** may be advantageously included between the channel area **474c** and the source/drain electrode **474a/474b**.

[0051] The flat layer **430** is configured on the device layer **420**, and the flat layer **430** includes a plurality of contact window openings **430a** for exposing parts of the foregoing active devices **470**. According to an embodiment of the invention, the material of the flat layer **430**, for example, is silicon dioxide, silicon nitride or silicon nitride oxide.

[0052] The first color filter layer **442** is configured on the flat layer **430**, and the first color filter layer **442** has a first pixel area **442a** and a first opening **442b**. The first opening **442b** is configured above a part of the contact window openings **430a**. The second color filter layer **444** is configured on the flat layer **430**, and the second color filter layer **444** has a second pixel area **444a** and a second opening **444b**. The second opening **444b** is configured above a part of the contact window openings **430a**. The third color filter layer **446** is configured on the flat layer **430**, and the third color filter layer **446** has a third pixel area **446a** and a third opening **446b**. The third opening **446b** is configured above a part of the contact window openings **430a**.

[0053] According to an embodiment of the invention, the first color filter layer **442** is a red color filter layer; the second color filter layer **444** is a green color filter layer; and the third color filter layer **446** is a blue color filter layer, all of which compose a color filter array layer. It is to be noted that the color filter array layer composed of the first, the second and the third color filter layers **442**, **444** and **446** are not only functioned as color filters, but also used as pixel defining areas for defining a plurality of first, second and third pixel

areas **442a**, **444a** and **446a**. Further, the color filter array layer can even be used as an etching mask for making the contact window openings **430a**.

[0054] Referring to FIG. 3, the first, the second and the third pixel electrodes **452**, **454** and **456** are disposed respectively in the first, the second and the third pixel areas **442a**, **444a** and **446a**. The first, the second and the third pixel electrodes **452**, **454** and **456** are respectively electrically connected to the active devices **470** via the contact window openings **430a** and the first, the second and the third openings **442b**, **444b** and **446b** respectively. According to an embodiment of the invention, the first, the second and the third pixel electrodes **452**, **454** and **456** are made of indium tin oxide ITO or indium zinc oxide IZO.

[0055] The first, the second and the third organic light emitting layers **462**, **464** and **466** are respectively configured on the first, the second and the third pixel electrodes **452**, **454** and **456**. According to an embodiment of the invention, the first, the second and the third organic light emitting layers **462**, **464** and **466** can be different in composition, i.e., the colors of the above organic light emitting layers **462**, **464** and **466** can be different, wherein the first organic light emitting layer **462** is a red organic light emitting layer; the second organic light emitting layer **464** is a green organic light emitting layer; and the third organic light emitting layer **466** is a blue organic light emitting layer, thus a better color saturation performance can be achieved.

[0056] According to another embodiment of the invention, the first, the second and the third organic light emitting layers **462**, **464** and **466** can also be identical in composition, i.e., the colors of the above organic light emitting layers **462**, **464** and **466** can be identical. The first, the second and the third organic light emitting layers **462**, **464** and **466**, for example, are white organic light emitting layers. Therefore, organic light emitting color filter layers of identical white color can be evaporated at the same time, thus the production procedure is simplified and the production cost is lowered accordingly.

[0057] In summary, the method for fabricating an AMOLED display device and the structure of such device according to the present invention has at least the following advantages:

[0058] 1. The present invention is adapted for skipping over the step of making pixel defining layers and the step of making etching masks for making the contact window openings, thus the present invention simplifies the fabricating process and lowers the production cost;

[0059] 2. Incorporating with organic light emitting layers of different colors, the color filter layers are able to enhance the color saturation performance;

[0060] 3. Organic light emitting layers of same color (white) can also be used according to the present invention for further lowering the production cost.

[0061] Other modifications and adaptations of the above-described preferred embodiments of the present invention may be made to meet particular requirements. This disclosure is intended to exemplify the invention without limiting its scope. All modifications that incorporate the invention disclosed in the preferred embodiment are to be construed as

coming within the scope of the appended claims or the range of equivalents to which the claims are entitled.

What is claimed is:

1. A method for fabricating an active matrix organic light emitting diode (AMOLED) display device, comprising:

providing a substrate;

configuring a device layer on the substrate, wherein the device layer comprising a plurality of active devices;

configuring a flat layer on the device layer;

configuring a first color photoresistant layer on the flat layer;

patterning the first color photoresistant layer to configure a first color filter layer and to define a first pixel area, and the first color filter layer having a first opening;

configuring a second color photoresistant layer on the flat layer;

patterning the second color photoresistant layer to configure a second color filter layer and to define a second pixel area, and the second color filter layer having a second opening;

configuring a third color photoresistant layer on the flat layer;

patterning the third color photoresistant layer to configure a third color filter layer and to define a third pixel area, and the third color filter layer having a third opening;

using the first, the second and the third color filter layers as masks for removing parts of the flat layer respectively under the first, the second and the third openings for configuring a plurality of contact window openings for exposing parts of the active devices;

configuring a first pixel electrode, a second pixel electrode and a third pixel electrode respectively in the first, the second and the third pixel areas, the first pixel electrode, the second pixel electrode and the third pixel electrode being respectively electrically connected with the active devices via the contact window openings; and

configuring a first organic light emitting layer, a second organic light emitting layer and a third organic light emitting layer respectively on the first pixel electrode, the second pixel electrode and the third pixel electrode.

2. The method according to claim 1, wherein the process of patterning the first, the second and the third color photoresistant layers comprises respectively patterning the first, the second and the third color photoresistant layers with a half-tone mask.

3. The method according to claim 1, wherein the first color filter layer is a red color filter layer; the second color filter layer is a green color filter layer; and the third color filter layer is a blue color filter layer.

4. The method according to claim 1, wherein the first, the second and the third organic light emitting layers are different in composition.

5. The method according to claim 4, wherein the first organic light emitting layer is a red organic light emitting layer; the second organic light emitting layer is a green organic light emitting layer; and the third organic light emitting layer is a blue organic light emitting layer.

6. The method according to claim 1, wherein the first, the second and the third organic light emitting layers are identical in composition.

7. The method according to claim 6, wherein the first, the second and the third organic light emitting layers are white organic light emitting layers.

8. An AMOLED display device, comprising:

a substrate;

a device layer, configured on the substrate, the device layer comprising a plurality of active devices;

a flat layer, configured on the device layer, the flat layer comprising a plurality of contact window openings for exposing parts of the active devices;

a first color filter layer, configured on the flat layer, having a first pixel area and a first opening, and the first opening being configured above a part of the contact window openings;

a second color filter layer, configured on the flat layer, having a second pixel area and a second opening, and the second opening being configured above a part of the contact window openings;

a third color filter layer, configured on the flat layer, having a third pixel area and a third opening, and the third opening being configured above a part of the contact window openings;

a first, a second and a third pixel electrodes respectively configured in the first, the second and the third pixel areas; the first, the second and the third pixel electrodes being respectively electrically connected with the active devices via the contact window openings; and

a first organic light emitting layer, a second organic light emitting layer and a third organic light emitting layer respectively configured on the first pixel electrode, the second pixel electrode and the third pixel electrode.

9. The AMOLED display device according to claim 8, wherein the first color filter layer is a red color filter layer; the second color filter layer is a green color filter layer; and the third color filter layer is a blue color filter layer.

10. The AMOLED display device according to claim 8, wherein the first, the second and the third organic light emitting layers are different in composition.

11. The AMOLED display device according to claim 10, wherein the first organic light emitting layer is a red organic light emitting layer; the second organic light emitting layer is a green organic light emitting layer; and the third organic light emitting layer is a blue organic light emitting layer.

12. The AMOLED display device according to claim 8, wherein the first, the second and the third organic light emitting layers are identical in composition.

13. The AMOLED display device according to claim 12, wherein the first, the second and the third organic light emitting layers are white organic light emitting layers.

14. The AMOLED display device according to claim 8, wherein the device layer further comprises a plurality of scan lines and a plurality of data lines, by which the active devices can be driven.

15. The AMOLED display device according to claim 8, wherein the active devices comprises thin film transistors (TFTs).

16. The AMOLED display device according to claim 15, wherein each of the TFTs comprises:

a silicon island, disposed on the substrate;

a gate-insulating layer, covering the silicon island;

a gate electrode, configured on the gate-insulating layer above the silicon island;

a source/drain electrode, configured in the silicon island under two sides of the gate electrode, a channel area being defined between the source/drain electrode;

an inter-layer dielectric (ILD) layer, configured covering the gate electrode and exposing a part of the source/drain electrode; and

a source/drain contact metal, electrically connected respectively with the source/drain electrode.

17. The AMOLED display device according to claim 16, wherein a lightly doped drain (LDD) area is further configured between the channel area and the source/drain electrode.

18. The AMOLED display device according to claim 8, wherein the first, the second and the third pixel electrodes are made of indium tin oxide (ITO) or indium zinc oxide (IZO).

* * * * *

专利名称(译)	制造有源矩阵有机发光二极管显示装置的方法和这种装置的结构		
公开(公告)号	US20070238218A1	公开(公告)日	2007-10-11
申请号	US11/308561	申请日	2006-04-07
[标]申请(专利权)人(译)	中华映管股份有限公司		
申请(专利权)人(译)	中华映管股份有限公司.		
当前申请(专利权)人(译)	中华映管股份有限公司.		
[标]发明人	TENG TE HUA CHEN CHIA CHIEN LU FANG YI WU BING WEI YANG YUN PEI		
发明人	TENG, TE-HUA CHEN, CHIA-CHIEN LU, FANG-YI WU, BING-WEI YANG, YUN-PEI		
IPC分类号	H01L51/40		
CPC分类号	H01L27/1214 H01L51/56 H01L27/3244 H01L27/322 H01L27/1288		
其他公开文献	US7482186		
外部链接	Espacenet USPTO		

摘要(译)

提供了一种用于制造AMOLED显示装置的方法。提供基板。在衬底上形成具有多个有源器件的器件层。在设备层上配置平坦层。第一，第二和第三颜色光敏层分别配置在平坦层上并被图案化以形成第一，第二和第三滤色器层。第一，第二和第三滤色器层分别限定第一，第二和第三像素区域，并用于蚀刻掩模以蚀刻平坦层以暴露部分有源器件。第一像素电极，第二像素电极和第三像素电极分别配置在所述像素区域中并与有源器件电连接。在所述像素电极上分别配置第一，第二和第三有机发光层。

